

Driven single nut with flange FAR-B-S

Rexroth connection dimensions

With seals,
preload class: C1, C2, C3
Tolerance grade T3²⁾, T5, T7

The unit consists of:
nut, angular-contact thrust ball bearing and
slotted nut NMZ

When in standstill, it can be relubricated
with NLGI Class 2 grease via the stationary
lube port of the bearing outer race

Note: Supplied only as complete
ball screw assembly.

d_0 = nominal diameter
 P = lead (R = right-hand)
 D_w = ball diameter
 i = number of ball track turns

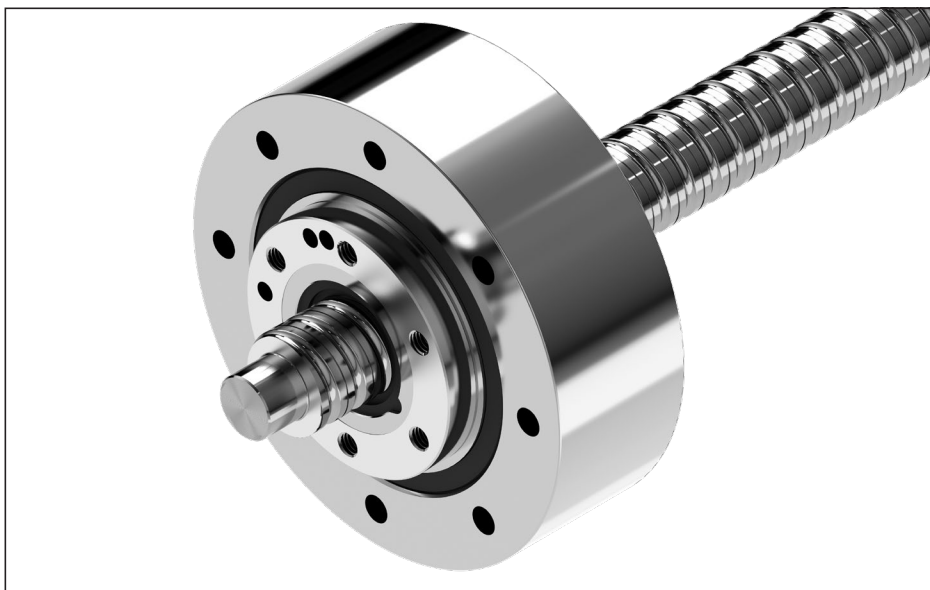

Ordering data:

BASA	40x20R x 6	FAR-B-S - 3	00	1	6	T5	R	51K300	51K300	1250	0	1
------	------------	-------------	----	---	---	----	---	--------	--------	------	---	---

Cat-egory	FAR size	Size $d_0 \times P \times D_w - i$	Part number Module	Load ratings ^{1) 4)}		Mass m_{FAR} (kg)	Mass moment of inertia J_{rotFAR} ($kg \cdot m^2 \cdot 10^{-4}$)	Frictional torque Bearing		Max. speed ³⁾ n_G (rpm)
				dyn. C (N)	stat. C ₀ (N)			M _{RL} (Nm)		
C	32	32 x 10R x 3.969 - 5	R2532 301 01	38,000	58,300	5.8	22.5	1.0	3 000	
		32 x 20R x 3.969 - 3	R2532 301 11	23,600	33,700	5.9	22.9			
		32 x 32R x 3.969 - 3	R2532 301 21	23,400	34,000	6.3	25.1			
C	40	40 x 10R x 6 - 5	R2532 401 01	73,400	109,300	7.3	42.7	1.2	2 800	
		40 x 20R x 6 - 3	R2532 401 31	45,500	62,800	7.5	43.9			
		40 x 40R x 6 - 3	R2532 401 41	44,400	62,300	8.4	50.7			
C	50	50 x 10R x 6 - 6	R2532 501 01	95,600	166,500	8.3	67.6	1.4	2 700	
		50 x 20R x 6.5 - 5	R2532 501 31	90,800	149,700	9.1	76.0			
		50 x 40R x 6.5 - 3	R2532 501 41	55,800	85,900	9.5	79.8			
C	63	63 x 10R x 6 - 6	R2532 601 01	106,600	214,300	12.8	139.0	2.3	2 300	
		63 x 20R x 6.5 - 5	R2532 601 11	100,700	190,300	13.5	156.4			
		63 x 40R x 6.5 - 3	R2532 601 21	64,100	114,100	13.9	161.6			

1) Load ratings calculated according to DIN ISO 3408-5

2) Tolerance grade T3 for sizes shown in table page 12

3) Limited by the max. speed of the bearing. Bearing pre-tensioned without external operating load. Duty cycle 25%; max. steady-state temp. +50 °C

4) The load ratings are valid for tolerance grade T3 and T5 only.

For other tolerance grades, please take into account the correction factor f_{ac} on page 133.

FAR rigidity levels

FAR size	Size $d_0 \times P \times D_w - i$	Rigidity		Overall rigidity of the nut unit (N/ μ m)		
		Screw R_S (Nm/ μ m)	Bearing R_{aL} (N/ μ m)	Preload class C1 R_G	Preload class C2 R_G	Preload class C3 R_G
32	32 x 10R x 3.969 - 5	141	860	320	350	380
	32 x 20R x 3.969 - 3	141	860	220	250	280
	32 x 32R x 3.969 - 3	141	860	220	240	270
40	40 x 10R x 6 - 5	211	950	390	420	450
	40 x 20R x 6 - 3	211	950	270	300	330
	40 x 40R x 6 - 3	211	950	270	290	330
50	50 x 10R x 6 - 6	345	1,050	490	520	560
	50 x 20R x 6.5 - 5	340	1,050	450	480	530
	50 x 40R x 6.5 - 3	340	1,050	320	350	390
63	63 x 10R x 6 - 6	569	1,150	560	600	640
	63 x 20R x 6.5 - 5	563	1,150	520	560	610
	63 x 40R x 6.5 - 3	563	1,150	390	420	460

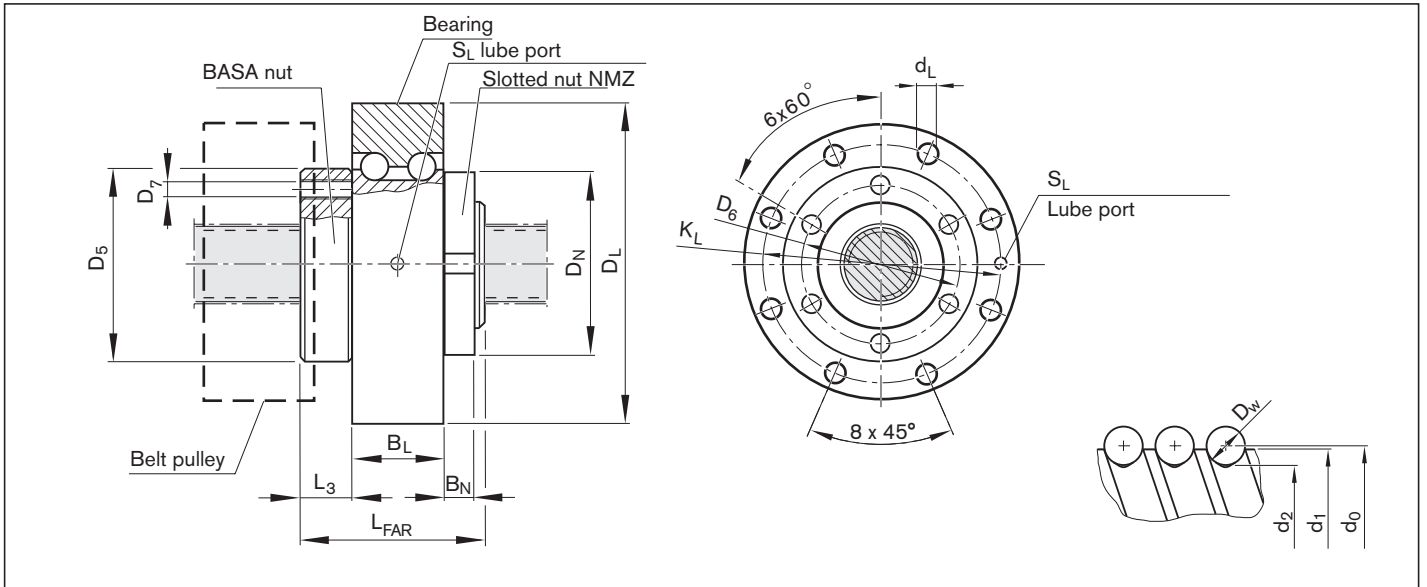

FAR size	Size $d_0 \times P \times D_w - i$	Dimensions (mm)													
		d_1	d_2	L_{FAR}	D_5 h6	D_6	D_7	L_3	D_L -0.018	B_L	K_L	d_L +0.3/-0.1	$S_L^{5)}$	D_N	B_N
32	32 x 10R x 3.969 - 5	31	27.9	77	80	65	M8	11	145	49	120	8.8	M6	75	16
	84														
	120														
40	40 x 10R x 6 - 5	38	33.8	80	93	80	M8	12	155	49	130	8.8	M6	92	18
	88														
	142														
50	50 x 10R x 6 - 6	48	43.8	90	105	90	M8	13	165	49	140	8.8	M6	105	18
	43.3		132												
	149														
63	63 x 10R x 6 - 6	61	56.8	100	130	110	M10	20	190	60	165	11.0	M6	120	20
	56.3		132												
	149														

5) Condition on delivery: lube ports S_L sealed by setscrews (M6).
The desired lube port can be opened by removing the set screw.